

# MOTORCYCLE TUNES

## *Amplified Speakers*



Featuring Amplifier By:  **ALPINE**®

Thanks for purchasing a Motorcycle Tunes Audio Systems.

Email pictures of your installation, and we will add them to our website. Send email to [motorcycltunes@aol.com](mailto:motorcycltunes@aol.com)  
Be sure to include the year, make, model of your bike, and any notes the installation that may help others.

**IMPORTANT:** These instructions are condensed general instructions. Please see the enclosed Alpine instructions for more information and complete instructions. Motorcycle Tunes is NOT responsible for any damage to your bike or equipment caused by improper installation or faulty equipment. Installation is not rocket science, these instructions are intended to be simple as possible so that anyone can install. If you are not comfortable with the installation process, we recommend talking with your local car audio shop about installing for you.

**CAUTION: DO NOT PLUG THE AMPLIFIER POWER PLUG INTO THE AMPLIFIER, UNTIL INSTRUCTED TO DO SO.**

**BELOW INSTRUCTIONS ARE TO BRIDGE THE AMPLIFIER FOR 2 SPEAKER HOOKUP – IF YOU PLAN ON USING WITH 4 SPEAKERS THEN YOU WILL NEED TO REFER TO THE INSTRUCTIONS IN THE ALPINE BOOKLET.**

### Speaker Mounting

**Step 1: Mounting the Speaker Clamps:** Get an idea where you want to mount the speakers. Mount the clamps to your bars. There will be a gap on the clamps that will tighten up when the speakers are installed..

*Important: Make sure the speakers will not interfere with your steering, or gauges.*

**Step 2: Mounting the Speakers:** Mount each speaker to the clamp and make sure they are secured, but do not apply too much torque to the nut. **The bottom mounting bolt is chromed stainless steel. The treads on this bolt can be stripped easily if the nut tightened too much, or if the nut is not perfectly aligned before tightening..** Run the speaker wires down to where you are going to mount the amplifier. You may want to run the Audio Adapter Cable at this time as well.

## AMPLIFIER AUDIO INPUT/REMOTE TURN ON PLUG

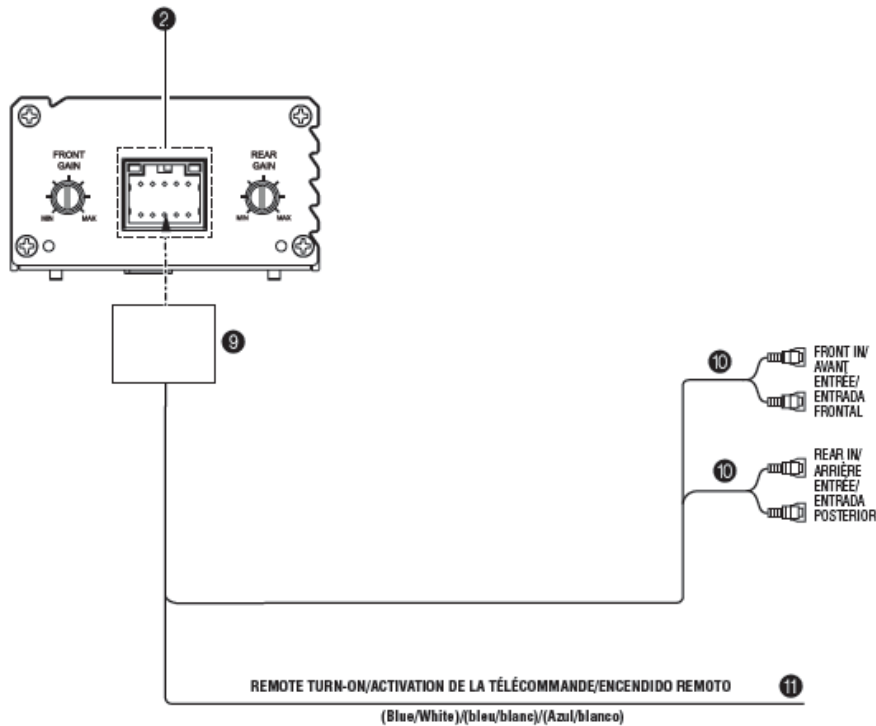

### Step 3. Amplifier Audio Input.

**Amplifier Audio Input Cable** – This is a short plug with 4 RCA plugs on it, ONE SET IS MARKED FRONT

**FOR A 2 SPEAKER SETUP, YOU WILL ONLY USE THE RCA PLUGS ON THE AMPLIFIER MARKED FRONT**

**Audio Adapter Cable** – This is a 6 foot long cable, one end has RCA plugs on it, the other end has a 3.5mm Jack on it.

Plug rca plugs on the audio adapter cable into the Front RCA plugs on the Amplifier Audio Input Cable. Plug the Amplifier adapter cable into the RCA amplifier harness input

**(ONLY USE THE AMPLIFIER RCA PLUGS MARKED FRONT, DO NOT PLUG INTO THE OTHER RCA PLUGS)**

Run the 3.5mm end of this cable up to where you want to mount the inline volume control.

or

If you elected to get the Bluetooth Receiver – Please Refer to the Bluetooth Receiver Instruction insert at this time.

THE BLUE/WHITE WIRE ON THIS PLUG IS NOT USED.

You can now plug the amplifier input/remote turn on cable plug into the amplifier slot.

### Step 4: In-Line Volume Control

– This is used to make adjustments to the volume while you ride. Plug the Male end of the above Amplifier Audio Input, into the Female Jack of the In-Line Volume Control. Most people use cable ties to mount this volume control to their handlebars.

The male end of the In-Line Volume Control will plug into the headphone jack or audio output jack of your audio device.

If you have an iPhone or Android Phone, you can go to the app store and download a third party speed based volume control, some are free some cost.

## AMPLIFIER POWER PLUG/SPEAKER OUTPUT PLUG

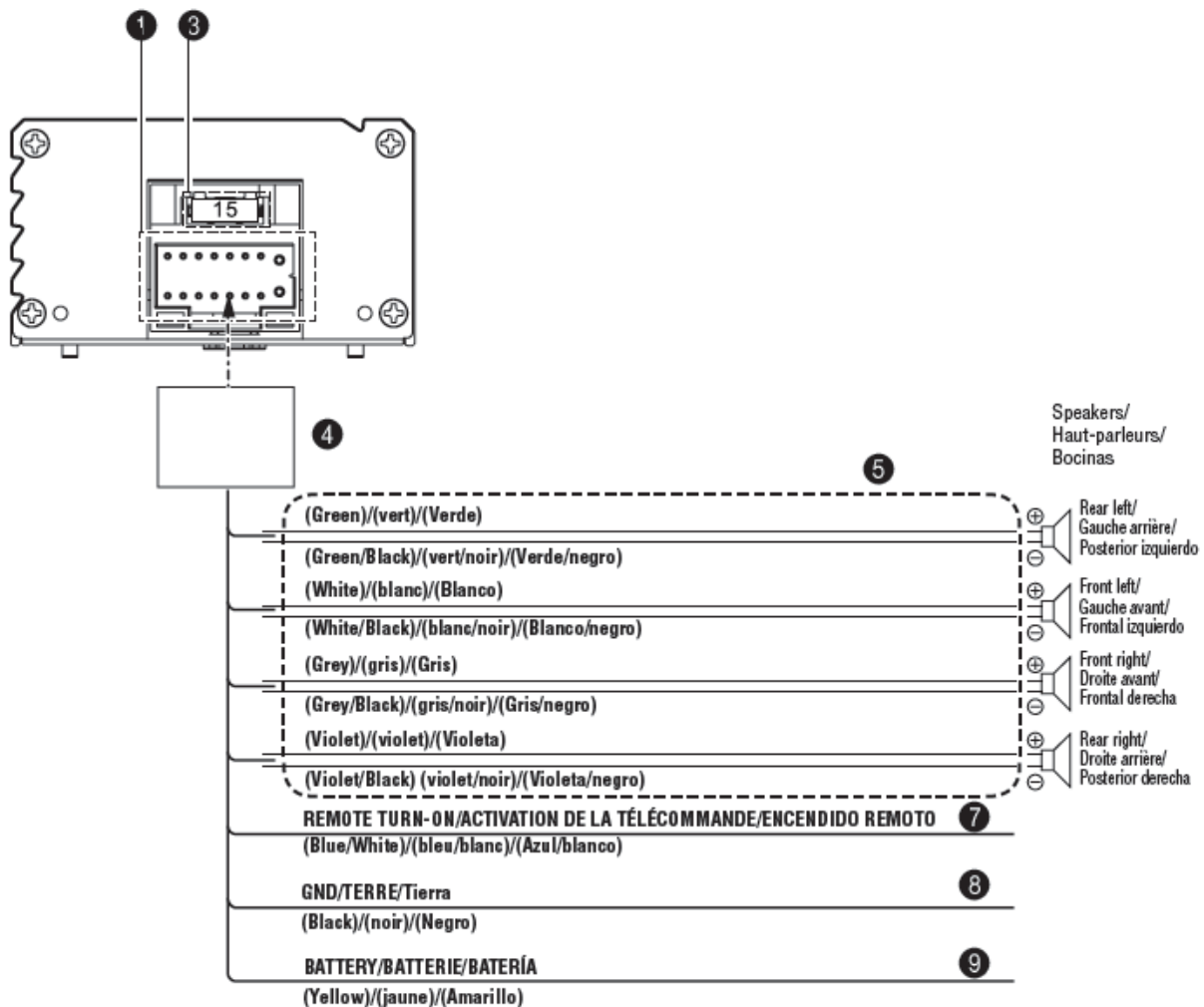

### Amplifier Power Plug

The Amplifier Power Plug also contains the Speaker Output wires with plenty of length for your custom install.

**DO NOT PLUG THE AMPLIFIER POWER PLUG INTO THE AMPLIFIER AT THIS TIME, YOU WILL BE INSTRUCTED WHEN TO DO SO.**

**Step 5: Yellow Wire (B+)** - This is the power wire. Hook this to the positive battery post.

**Step 6: Black Wire (Ground)** – Hook this wire to the frame of the motorcycle. .

**Step 7: Blue/White Wire (Remote)** – This is the wire that will turn the amplifier on/off

with your key. Hook this to a switched and fused 12v power source on your bike. You can use a test light to find a wire that turns on/off with your key, such as a headlight wire, or you can add a mechanical switch inline with a 12 volt source to activate the amplifier. This is what will turn the amplifier on/off with your key.

**Step 8:** Run the power plug up to where you are going to install the amplifier.

**Amplifier Speaker Output Plug** – This is a small 4 prong plug, with 4 short speaker wires on it.

**Step 9: Hooking up the speaker wires to the Amplifier Speaker Output Plug.**

Left Chrome Speaker **Red** to the Solid White

Left Chrome Speaker **Black** to Green/Black-

Right Chrome Speaker **Red** to Violet

Right Chrome Speaker **Black** to Grey/Black

You can now plug Amplifier Speaker Output Plug into the amplifier speaker output (slot 4 in the above Amplifier Identification Chart)

**Step 10. Check Wiring.**

**RECHECK YOUR WIRING, AND MAKE SURE EVERYTHING IS HOOKED UP CORRECTLY.**

There are two power wires on the Amplifier Power Plug, The red wire, should have a fuse inline before connecting to the positive battery terminal.

The blue/white wire (on the RCA input side of the amp) should be hooked to a switched and FUSED 12v power source that turns on/off with the key.

The Black wire should be hooked to the frame of your bike

You can now plug the Amplifier Power Plug/Speaker Plug into the Power Port of the Amplifier

Make sure that all wires are away from hot areas, and that everything is secured to your bike. Before your turn on the power, make sure that your devices volume is turned down. You can damage your speakers/amplifier if your device is at full or loud volume when the amp is turned on. You will always want to start off with a low volume and build up to a louder volume. This will prolong the life of your speakers/amplifier. Everything should now be hooked up correctly. You can now use the speakers.

When you turn the key on, the amplifier light should also come on, this indicates that it is properly hooked up.

**CAUTION: HOOKING THE AMPLIFIER UP INCORRECTLY CAN CAUSE PROPERTY DAMAGE OR PERSONAL INJURY.**

**STEP 11. Setting up the amplifier.** Before you mount the amplifier, you want to get set the settings because it may not be easily assessable once installed.

Make sure the volume on your audio device is turned down, then Plug the 3.5mm male end of the Volume Control into the headphone jack or audio output jack of your device.

Turn on the Key, this will power up the amplifier

Turn on your audio device, and push play, turn you can adjust the volume on your device and use the the in-line volume control.

The only setting on the amplifier you should worry about is the gain dial, for most people turning this up about ¾ is the sweet spot, but it is a personal preference. See Amplifier Setting Chart for how to set gain.

**Step 12 Mounting the Amplifier**

Securely mount the amplifier to the motorcycle. Two cable ties are included, underside of the amplifier has slots for the cable ties to secure the amplifier. The Amplifier is not waterproof and should be mounted in a saddlebag or travel trunk.

**Step 13: Safety Check**

**Important:** Make sure that your driving ability is not hindered by the items added to your bike, and that you can safely operate your bike before your road test the equipment. Motorcycle Tunes yields all responsibility of any damage caused by or any damage that may result from the Motorcycle Tunes audio system. When purchasing our item, you are agreeing to release Motorcycle Tunes of all legal liabilities of all products/advice given through website, instructions, email, or phone. As the purchaser, you are agreeing to assume all responsibility of the items once they have been shipped.